

TS-3000 CE

Over-wrapping Machine

The TS3000 overwrapping machine is specially designed for cosmetic, pharmaceutical, vitamin and gift accessories type industries.

It is manufactured to meet industrial specifications. Change-over between different products is about 20 minutes. It is equipped with PLC and touch screen to make the change-over process much easier.

The TS-3000 is a user-friendly, robust and reliable low maintenance solution to overwrapping. Optional conveyors can be added to connect to upstream or downstream equipments.

FEATURES:

- User friendly
- Assorted pack size capability
- Low maintenance and running costs
- Touch screen control panel, able to store up to 5 preset sizes
- Variable speed infeed conveyor
- Fast change-over

OPTIONAL FEATURES:

- Centralized automatic grease pump
- Tear tape applicator
- I-mark sensor for printed Bopp film



TS-3000 right angle infeed



TS-3000 inline infeed

TS-3000 CE

Overwrapping machine

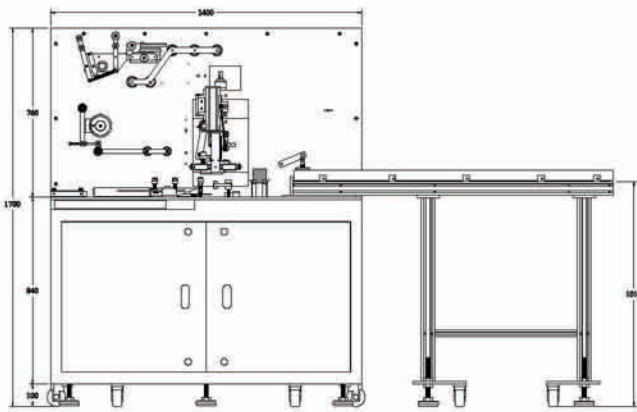

Technical Specifications :

Machine Dimension : 2450(L) x 1325(W) x 1700(H)mm
 Power : 220/380V c.a. 3 Phase 50/60Hz 2500W
 Air requirements : 80 l./min - 6 bars
 Output : Max 40pcs/min., depending on product size
 Machine Weight : NW 950KGS, GW 1150KGS
 Crate Size : 5.68CBM
 Temp./Humidity : 5-40C / 90%max

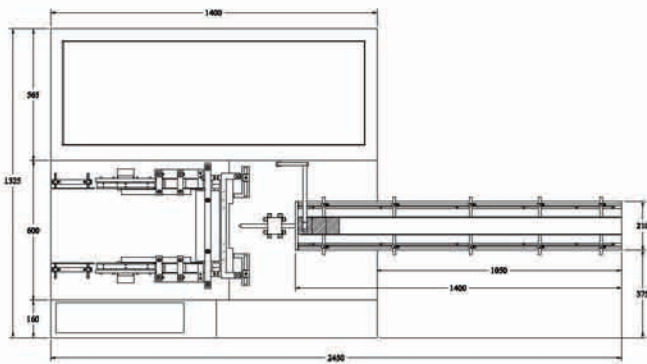

All extreme sizes are not suitable in the same pack

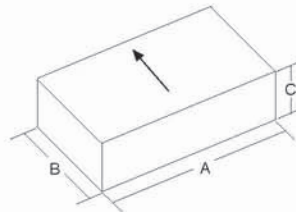

BOX SIZES	A	B	C
MAX	220	115	75
MIN	70	35	15

Bopp film thickness = 25 - 40 micron

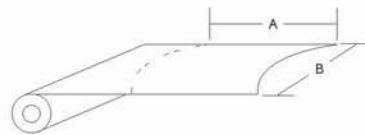

FILM SIZES	A	B
MAX	445	325
MIN	150	125

RIGHT ANGLE
INFEED
FLOW DIAGRAM

INLINE INFEED
FLOW DIAGRAM

